

Adjustable Shell Reamers Type H

Example of Application

Inline Reaming of a Bearing Tunnel

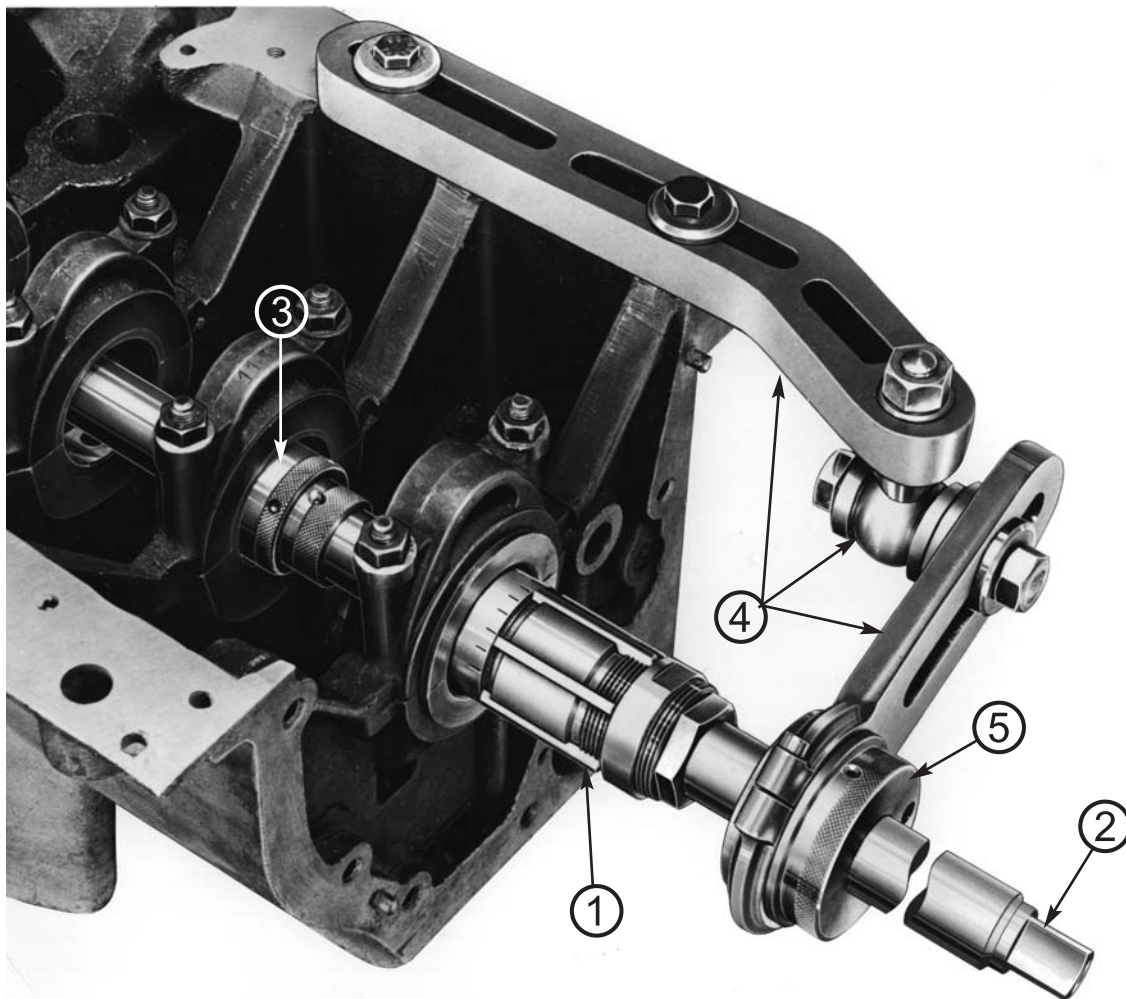

Components

- ① Adjustable Shell Reamer Type H
- ② Tool Bar
- ③ Expanding Guide Bush
- ④ External Bearing Support
- ⑤ Plain Bearing Bush

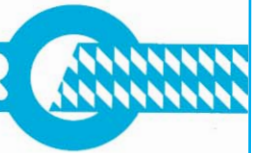

Adjustable Shell Reamers Type H

Application Range

The reamer for reaming aligned holes, especially widely spaced holes

Description

Right-hand cutting shell reamer with adjustable blades and a through-hole for installing a tool bar for guiding and moving the reamer.

Adjustment is easily done with two round nuts which raise or lower the cutting blades by moving them along tapered seatings. The front nut is provided with a scale for ease of adjusting of the desired cutting diameter. One graduation mark on the scale corresponds to a change in the cutting diameter of 0.02 mm.

A clamping spring screwed into the through-hole of the reamer ensures that the reamer is taken along when the tool bar is advanced and turned.

To place the reamer on the tool bar, slide the reamer onto and along the tool bar while at the same time rotating the reamer in direction of cut.

In case that a very rigid connection of the reamer to the tool bar is required, the clamping spring can be replaced by a clamping shell that locks the reamer to the tool bar.

Expandable guide bushes available for insertion into the bores to align the tool bar in centerline with the bores. See page 5 for more details.

An external bearing support is available for guiding the tool bar in front of a bore. See page 6 for more details.

Technical Details



Size	Range Ø mm	Bore Ø d mm	Length Reamer L1 mm	Length Blades L2 mm	Nuts WAF mm	Blades Qty	Reamer Weight kg
H 36	36 - 38	20	96	44	32	6	0,370
H 38	38 - 41	20	99	44	34	6	0,450
H 41	41 - 44	20	104	48	38	6	0,590
H 44	44 - 47	25	104	48	40	6	0,590
H 47	47 - 51	25	108	48	43	6	0,760
H 51	51 - 54	30	108	52	47	5	0,830
H 54	54 - 58	30	113	52	47	6	0,930
H 58	58 - 62	30	113	52	53	6	1,180
H 62	62 - 65	35	114	52	58	8	1,290
H 65	65 - 69	35	118	57	58	8	1,490
H 69	69 - 73	40	118	57	64	8	1,790
H 73	73 - 78	40	123	57	68	8	1,970
H 78	78 - 83	45	124	57	70	8	2,110
H 83	83 - 88	45	124	60	78	8	2,750
H 88	88 - 93	50	124	60	83	8	3,000
H 93	93 - 99	50	127	60	83	10	3,490
H 99	99 - 105	50	127	60	*	10	4,200
H 105	105 - 111	50	127	60	*	10	5,040

* Adjustment of the nuts with hook wrench..

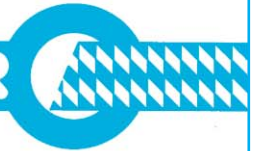

Adjustable Shell Reamers Type H Standard Version and Hard Chrome Version

Description

The blades of the standard reamers type H are made of a special steel with excellent cutting properties.

In addition to the standard "special steel" version with uncoated blades, Hunger has also a "hard chrome" version, in which the blades are coated with hard chrome.

The hard chrome coating has a low low coefficient of friction.

Reamers in the "hard chrome" version are therefore particularly suitable for reaming materials with a high wear-tendency and materials that tend to stick and form built-up edges.

The production of reamers with hard chrome coated blades and hard chrome coated spare blades has been discontinued.

Remaining stocks of almost all reamer sizes are still available while stocks last.

The "hard chrome" version is replaced by the advanced "DLC" version, in which the blades are coated with diamond-like carbon (DLC).

See page 4 for details.

Ordering Information

Size	Reamer		Replacement Blades*		Spare Nut with Scale P/N	Spare Clamping	
	Special Steel P/N.	Hard Chrome P/N.	Special Steel P/N	Hard Chrome P/N.		Spring P/N.	Shell P/N
H 36	150 36 000	151 36 000	150 36 400	151 36 400	150 36 520	150 20 600	150 20 650
H 38	150 38 000	151 38 000	150 38 400	151 38 400	150 38 520	150 20 600	150 20 650
H 41	150 41 000	151 41 000	150 41 400	151 41 400	150 41 520	150 20 600	150 20 650
H 44	150 44 000	151 44 000	150 44 400	151 44 400	150 44 520	150 25 600	150 25 650
H 47	150 47 000	151 47 000	150 47 400	151 47 400	150 47 520	150 25 600	150 25 650
H 51	150 51 000	151 51 000	150 51 400	151 51 400	150 51 520	150 30 600	150 30 650
H 54	150 54 000	151 54 000	150 54 400	151 54 400	150 54 520	150 30 600	150 30 650
H 58	150 58 000	151 58 000	150 58 400	151 58 400	150 58 520	150 30 600	150 30 650
H 62	150 62 000	151 62 000	150 62 400	151 62 400	150 62 520	150 35 600	150 35 650
H 65	150 65 000	151 65 000	150 65 400	151 65 400	150 65 520	150 35 600	150 35 650
H 69	150 69 000	151 69 000	150 69 400	151 69 400	150 69 520	150 40 600	150 40 650
H 73	150 73 000	151 73 000	150 73 400	151 73 400	150 73 520	150 40 600	150 40 650
H 78	150 78 000	151 78 000	150 78 400	151 78 400	150 78 520	150 45 600	150 45 650
H 83	150 81 000	151 81 000	150 81 400	151 81 400	150 81 520	150 45 600	150 45 650
H 88	150 82 000	151 82 000	150 82 400	151 82 400	150 82 520	150 50 600	150 50 650
H 93	150 83 000	151 83 000	150 83 400	151 83 400	150 83 520	150 50 600	150 50 650
H 99	150 84 000	151 84 000	150 84 400	151 83 400	150 84 520	150 50 600	150 50 650
H 105	150 85 000	151 85 000	150 85 400	151 83 400	150 85 520	150 50 600	150 50 650

*Replacement blades are supplied in matched sets.

The blades are finish ground, so no grinding is required after the blades are inserted into the reamer body.

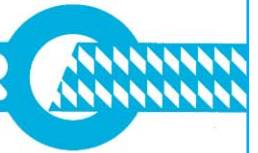

Adjustable Shell Reamers Type H DLC Version

Description

The blades of the reamers type H version DLC are coated with a diamond-like hard material layer, which is applied in a complex PVD process.

The DLC coating is characterized by extreme hardness, wear resistance and smoothness (very low friction). At the same time, the sharpness of the cutting edges is preserved because the DLC coating is extremely thin.

The DLC version of the reamers type H reamers is therefore ideal for reaming aluminum alloys, copper alloys (bronze and brass) as well as materials with a high wear effect and materials that tend to stick and form built-up edges

Ordering Information

Size	Reamer DLC P/N	Replacement Blades DLC P/N	Spare Nut with scale P/N	Spare Clamping	
				Spring P/N	Shell P/N
H 36	158 36 000	158 36 400	150 36 520	150 20 600	150 20 650
H 38	158 38 000	150 38 400	150 38 520	150 20 600	150 20 650
H 41	158 41 000	158 41 400	150 41 520	150 20 600	150 20 650
H 44	158 44 000	158 44 400	150 44 520	150 25 600	150 25 650
H 47	158 47 000	158 47 400	150 47 520	150 25 600	150 25 650
H 51	158 51 000	158 51 400	150 51 520	150 30 600	150 30 650
H 54	158 54 000	158 54 400	150 54 520	150 30 600	150 30 650
H 58	158 58 000	158 58 400	150 58 520	150 30 600	150 30 650
H 62	158 62 000	158 62 400	150 62 520	150 35 600	150 35 650
H 65	158 65 000	158 65 40	150 65 520	150 35 600	150 35 650
H 69	158 69 000	158 69 400	150 69 520	150 40 600	150 40 650
H 73	158 73 000	158 73 400	150 73 520	150 40 600	150 40 650
H 78	158 78 000	158 78 400	150 78 520	150 45 600	150 45 650
H 83	158 81 000	158 81 400	150 81 520	150 45 600	150 45 650
H 88	158 82 000	158 82 40	150 82 520	150 50 600	150 50 650
H 93	158 83 000	158 83 400	150 83 520	150 50 600	150 50 650
H 99	158 84 000	158 84 400	150 84 520	150 50 600	150 50 650
H 105	158 85 000	158 85 400	151 83 400	150 50 600	150 50 650

* Replacement blades are supplied in matched sets.
The blades are finish ground, so no grinding is required after the blades are inserted into the reamer body.

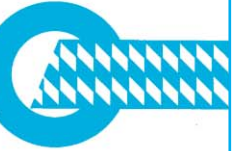

Tool Bars

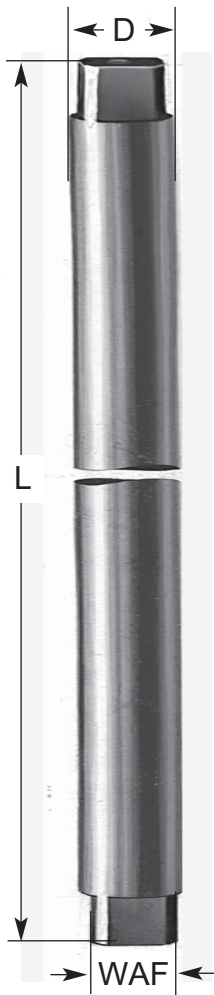

Application

A tool bar is required to guide and guide the reamer

Description

The tool bar has a square at each to which a tap wrench can be attached to rotate and advance the reamer that is placed on the tool bar.

The tool bars are precision ground so that the reamer is guided precisely in every position along the tool bar.

Ordering Information

Standard Tool Bar*		Diameter D mm	Length L mm	Square WAF mm	Weight kg
P/N	for Reamer Sizes				
152 20 101	H 36 - H 41	20	1000	13	2,420
152 25 101	H 44 - H 47	25	1000	13	3,740
152 30 121	H 51 - H 58	30	1200	16	6,540
152 30 151	H 51 - H 58	30	1500	16	12,000
152 35 121	H 62 - H 65	35	1200	18	8,750
152 40 151	H 69 - H 73	40	1500	18	14,400
152 45 151	H 78 - H 83	45	1500	22	18,110
152 50 171	H 88 - H 105	50	1700	22	25,200

* Customized tool bars are available in any desired length.

Expandable Guide Bushes for the Tool Bars

Application

The guide bush is clamped into one of the holes to keep the toolbar centered and aligned with the hole.

Description

The guide bushes are equipped with clamping wedges that can be adjusted radially outward by means of an adjusting ring to clamp the guide bush in the bore.

Ordering Information



Expandable Guide Bush		Bore d mm	Clamping Diameter Range D mm	Weight kg
P/N.	Suitable for Reamer Sizes			
153 20 000	H 36 - H 41	20	35,5 - 54	0,200
153 25 000	H 44 - H 47	25	43,5 - 62	0,300
153 30 000	H 51 - H 58	30	49,5 - 74	0,410
153 35 000	H 62 - H 65	35	61,5 - 83	0,620
153 40 000	H 69 - H 73	40	68,5 - 93	0,800
153 45 000	H 78 - H 83	45	77,5 - 105	1,100
153 50 000	H 88 - H 105	50	87,5 - 127	1,550

External Bearing Support

Application

The universal bearing support is designed to locate a plain bearing bush in front of a hole for perfect alignment of the tool bar

Description

The plain bearing bush is locked in a clamp arm that is connected by a ball joint to a mounting base that is attached to the work piece.

Both the clamp arm and ball joint are adjustable to ensure proper alignment.

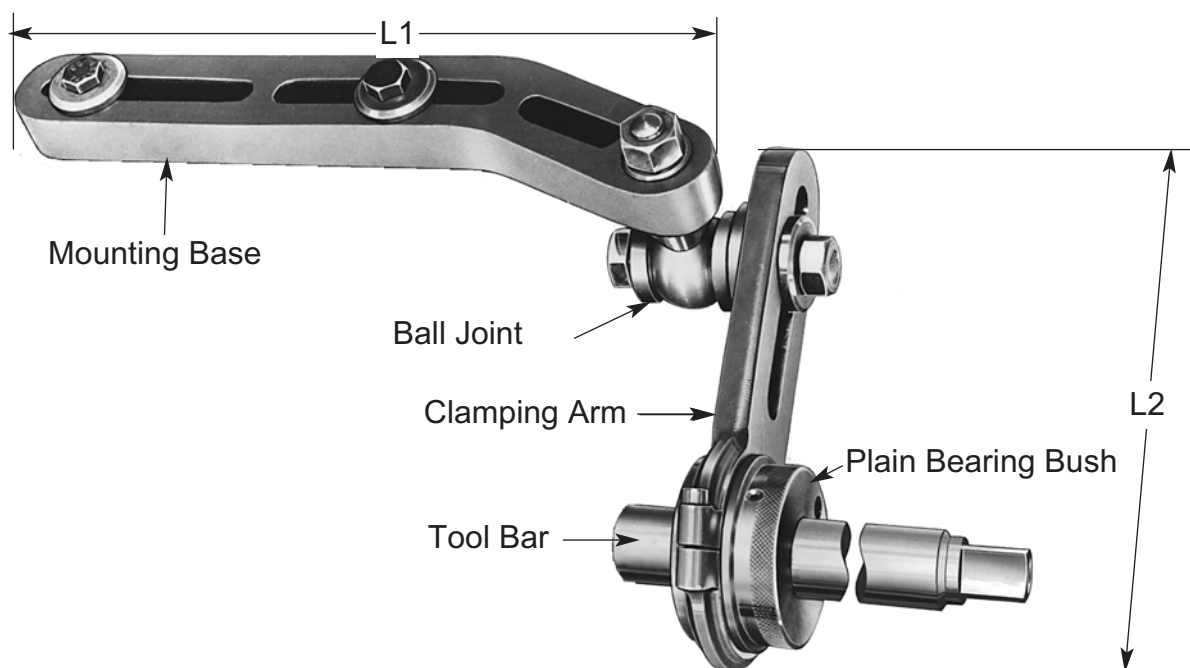

Ordering Information

Bearing Support			Components						
Size	P/N	Weight kg	Mounting Base			Clamping Arm			Ball Joint
			Size	P/N	L1 mm	Size	P/N	L2 mm	P/N
IA	156 11 100	3,140	IA	156 11 110	330	IA	156 11 120	210	156 11 130
IIA1	156 12 102	5,100	IIA	156 12 110	400	IA	156 11 120	210	156 11 130

Plain Bearing Bushes for Clamping Arm			
Size	P/N	Suitable for Bar Diameter	Weight kg
IA/20	156 21 200	20 mm	0,920
IA/25	156 21 250	25 mm	0,880
IA/30	156 21 300	30 mm	0,820
IA/35	156 21 350	35 mm	0,750
IA/40	156 21 400	40 mm	0,650
IA/45	156 21 450	45 mm	0,600
IA/50	156 21 500	50 mm	0,550

Ludwig Hunger Werkzeug- und Maschinenfabrik GmbH

Graefelfinger Str. 146
81375 Munich/Germany

Tel: +49 (0)89 7091-0
Fax: +49 (0)89 7091-26

sales@ludwig-hunger.de
www.ludwig-hunger.de